

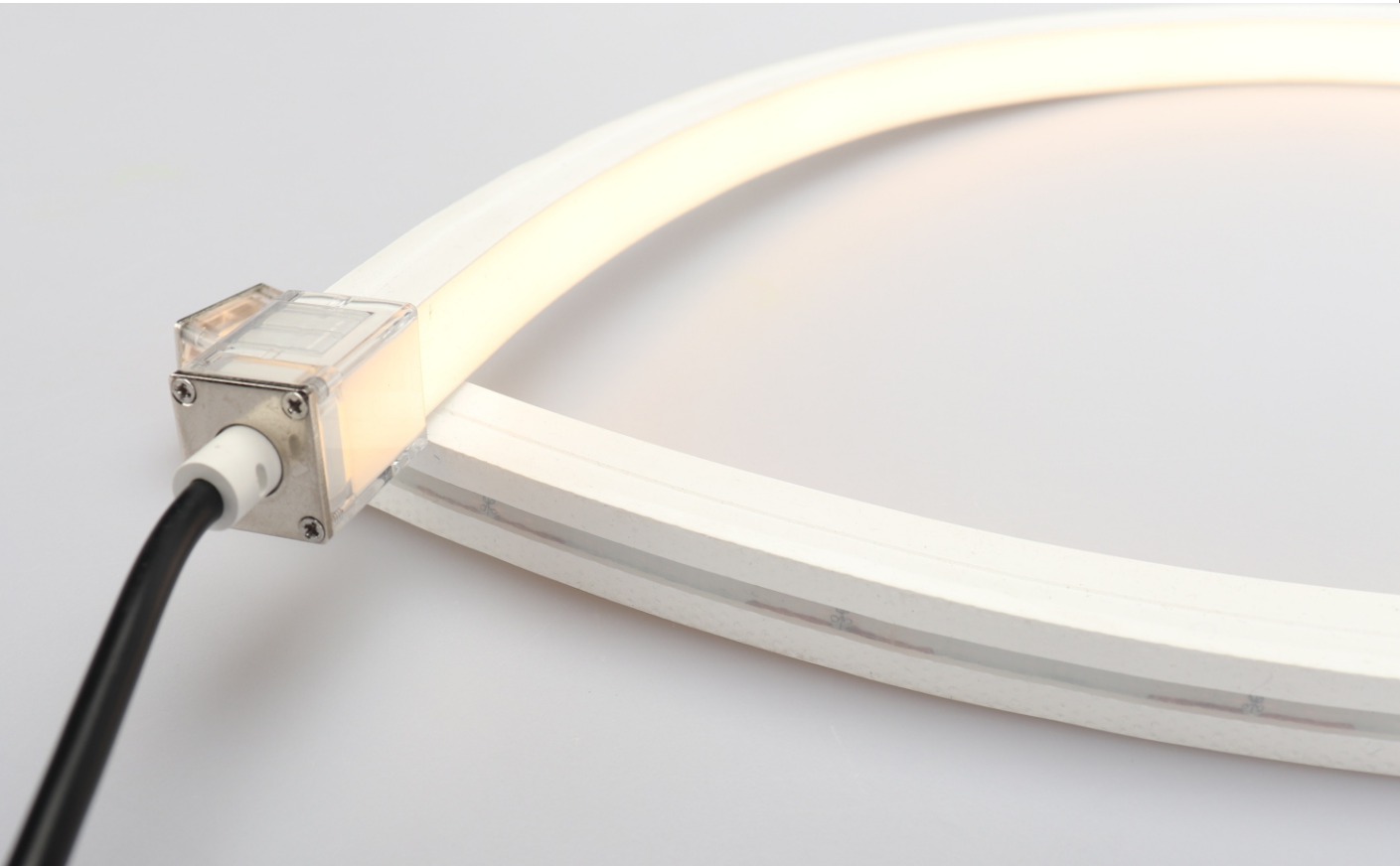

LED NEON FLEX SPECIFICATION

Uneon UNS-TOP-1615-W40-15-CC



- Regular power 5W/m, 10W/m and 15W/m for option
- Max length 35 meters with one end power
- Soldering-free and silicone end cap
- Eight CCT optional from 2100K to 6150K

- 2100K 2400K 2700K 3000K 3550K 4050K 5050K 6150K
- 2500K 5800K

- R P G B Y RGE BGRW



- One Bin
- CRI >90
- Solvent resistant
- Saltwater resistant
- UV protected
- Cuttable
- 50000 hours Lifetime
- LM80 Compliant
- 3 YEAR WARRANTY

Dimensions & Waterproof

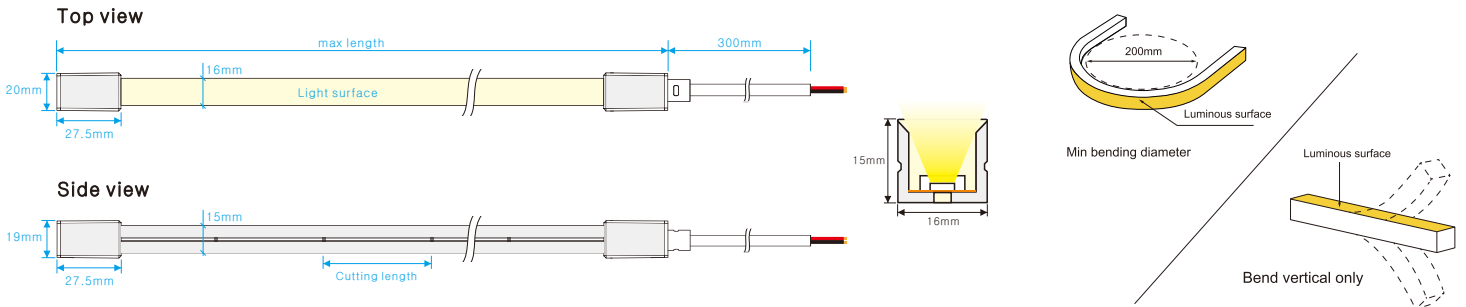

Product specification

Voltage	DC24 V
CRI/Ra	>90
Ambient temperature	-25°C~45°C
Color Type	Cutting length(mm)
Single color	50mm
Tunable white	50mm
RGB color	CV: 62.5mm / CC: 125mm
RGBW color	CV: 62.5mm / CC: 125mm

Note: CV means Constant Voltage, CC means Constant Current.

Polar curve (The data base on 15W 6000K)

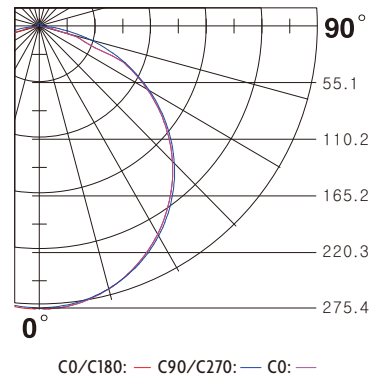

White color parameters

Part Number	CCT (K)	Low power(5w/m)		Medium power(10w/m)		High power(15w/m)	
		(lm/m)	(max length)	(lm/m)	(max length)	(lm/m)	(max length)
▶ UNS-TOP-1615-W21	2000-2200K	240.3	27m	459.9	17m	627.5	14m
▶ UNS-TOP-1615-W24	2300-2500K	242.0	27m	468.1	17m	659.7	14m
▶ UNS-TOP-1615-W27	2600-2800K	285.8	27m	552.7	17m	771.5	14m
▶ UNS-TOP-1615-W30	2900-3100K	286.3	27m	539.3	17m	766.9	14m
▶ UNS-TOP-1615-W35	3400-3700K	300.7	27m	583.9	17m	815.8	14m
▶ UNS-TOP-1615-W40	3800-4300K	294.1	27m	573.4	17m	807.0	14m
▶ UNS-TOP-1615-W50	4800-5300K	297.8	27m	570.3	17m	793.9	14m
▶ UNS-TOP-1615-W60	5900-6400K	293.9	27m	572.9	17m	782.6	14m

Tunable color parameters

Part Number	CCT (K)	Low power(5w/m)		Medium power(10w/m)		High power(15w/m)	
		(lm/m)	(max length)	(lm/m)	(max length)	(lm/m)	(max length)
▶ UNS-TOP-1615-TW	2500-2900K	133.0	5m	274.0	5m	363.7	5m
▶ UNS-TOP-1615-TW	5000-5800K	143.9	5m	295.1	5m	387.2	5m
▶ UNS-TOP-1615-TW	3500-4200K	279.5	5m	569.6	5m	766.2	5m

RGB & RGBW color parameters

Part Number	Color (nm)	Low power(5w/m)		Medium power(10w/m)		High power(15w/m)	
		(lm/m)	(max length)	(lm/m)	(max length)	(lm/m)	(max length)
▶ UNS-TOP-1615-R	Red(620-625nm)	111.6	35m	237.5	23m	323.2	18m
▶ UNS-TOP-1615-G	Green(515-525nm)	308.0	27m	548.2	17m	697.4	14m
▶ UNS-TOP-1615-B	Blue(460-465nm)	57.0	27m	106.9	17m	148.6	14m
▶ UNS-TOP-1615-Y	Yellow(585-595nm)	25.6	35m	44.4	23m	61.0	18m
▶ UNS-TOP-1615-P	Pink	116.7	27m	224.5	17m	302.2	14m
▶ UNS-TOP-1615-RGB-CV	RGB	147.8	5m	267.8	5m	323.5	5m
▶ UNS-TOP-1615-RGBW-CV	RGBW	189.5	5m	366.0	5m	496.4	5m
▶ UNS-TOP-1615-RGB-CC	RGB:320lm/m	R:66lm/m G:220lm/m B:35lm/m				Max length 13m	
▶ UNS-TOP-1615-RGBW-CC	RGBW:547lm/m	R:63.8lm/m G:192lm/m B:57.5lm/m W: 249lm/m				Max length 10m	

Note: CV means Constant Voltage, CC means Constant Current.

Installation of solder-free connector with cable

Explosive drawing of Solder-free connector with cable

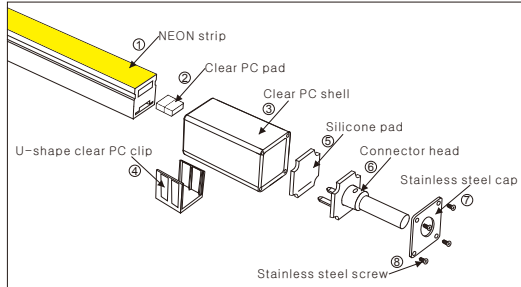

Cable outlet

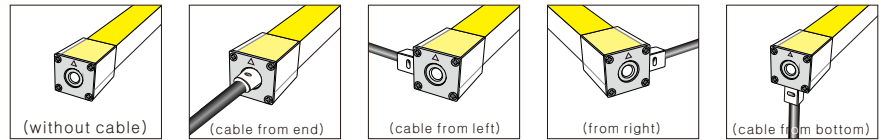

Note:

1. The same installation step suit for different outlet cable of the connector
2. Please keep the cutting place as flat as possible to achieve better waterproof effect.
3. This installation instruction is suitable of all the solder-free connector with similar structures.

Installation instruction of Solder-free connector with cable

Step 1:
Insert the clear PC pad into the hole of the NEON strip

Step 2:
Insert NEON strip into the clear PC shell

Step 3:
Install the U-shape clear PC clip on the bottom

Step 4:
Insert the connector head into the silicone pad

Step 5:
Insert the connector head into the NEON strip, please make sure the connector plug on the back of PCB soldering spot

Step 6:
Use screws to fix the stainless steel cap on the clear PC shell

Step 7:
Finish the whole installation of NEON strip end cap with cable

Installation of solder-free connector without cable

Explosive drawing of Solder-free connector without cable

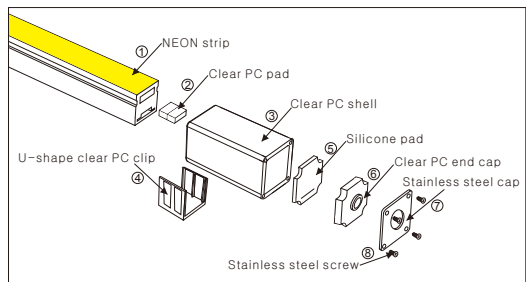

Installation instruction of Solder-free connector without cable

<p>Step 1: Insert the clear PC pad into the hole of the NEON strip</p>	<p>Step 2: Insert NEON strip into the clear PC shell</p>	<p>Step 3: Install the U-shape clear PC clip on the bottom</p>	<p>Step 4: Press the silicone pad into the Clear PC shell</p>
<p>Step 5: Press the clear PC end cap into the Clear PC shell</p>	<p>Step 6: Use screws to fix the stainless steel cap on the clear PC shell</p>	<p>Step 7: Finish the whole installation of NEON strip end cap without cable</p>	

Accessory



IP65 Solder-free endcap

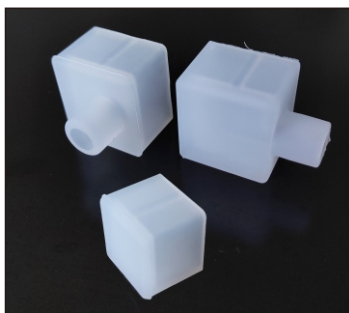

IP67 Silicone end cap

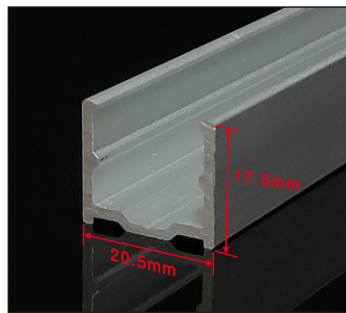

Mounting clip(length: 2cm)
Mounting channel(length: 1m, 2m,3m)



Scissors with angular scale

NOTE: IP65 version, solderless endcap fix by screw, more convenient; IP67 version, silicone endcap fix by silicone glue, more reliable.

Installation

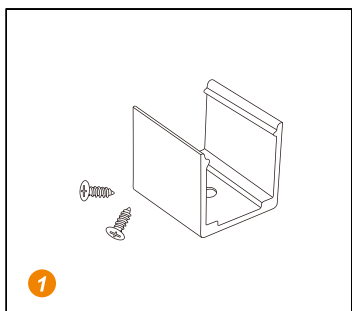

1 Prepare the screws and mounting clips

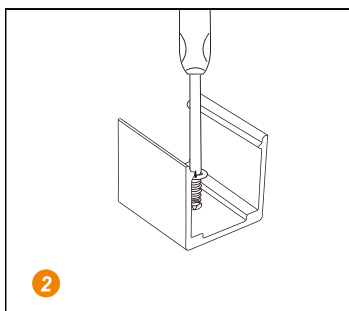

2 Adjust the fixed clips to the appropriate place, use a screwdriver to fix the screw.

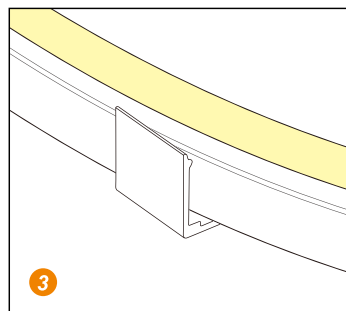

3 Put the light emitting surface upwards, then insert the LED strip into the fixed clips.

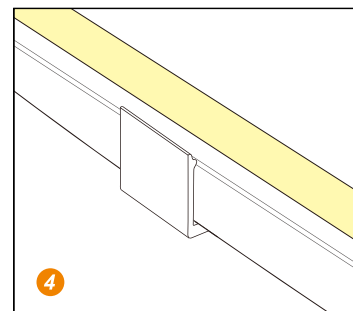

4 Fix NEON strip completely into the fixed clip.