

# Сенсорный пульт LT-T2 (для MIX-ленты)



T2 is the 2.4GHZ RF wireless synchronization color temperature controller which adopts LTECH multiple global initiate technology, the control system consists of two parts, the RF remote control and the receiver, realize the signal synchronization on unlimited receivers within effective distance, a very good solution for the LED project needs sync control wirelessly.

Can RF remote the functions of color temperature dimming, quick color temperature/brightness selection, DIY and delay off and so on. User-friendly color wheel for color temperature adjustment, unique LED state light for sync change indicated, user can simply know the LED working state from distance by checking the remote control.

Receiver can automatically adapt to the input voltage of DC 5V-24V. widely used for all LED lights with current-limiting resistance, such as single color LED module, LED tape and SMD flexible strip and so on.

## 1. Technical Specs:

### Remote Control

- Model: T2
- Input Voltage: DC5V Built-in Lithium Battery
- Working Current: <30mA
- Working Frequency: 2.4GHZ
- RF Remote Distance: 30m
- Remote Option: Sync Control
- Battery Capacity: 1000mAh
- Standby Time: 6 Months
- Normal Using Time: 30 Days
- Dimensions: L145×W55×H22(mm)
- Package Size: L168×W102×H28(mm)
- Weight (G.W.): 200g

### Receiver

- Model: T2-5A
- Power Supply Chosen: DC CV SMPS
- Input Voltage: DC5V~DC24V
- Max Current Load: 5A × 2CH
- Max Output Power: 50W/120W/240W(5V/12V/24V)
- Dimming Range: 5~100%
- Sync Quantity: No Quantity Limit
- Compatible Remote Control: T1/T2/T2M
- Working Temperature: -30℃~55℃
- Dimensions: L175×W44×H30(mm)
- Package Size: L178×W48×H33(mm)
- Weight (G.W.): 110g

## 2. Performance Features:

1. Adopt 2.4GHZ RF wireless transmission technology, which is applicable for license and patent free worldwide.
2. Built-in with dual-core driver, make it 10 times of processing speed. can process the wireless data transmission in complicated and multiple levels.
3. Advanced RF wireless sync control technology, no sync signal wire between receivers, sync capability is stable and reliable.
4. The remote control adopts the capacitive touch control technology on the circle, make the color temperature adjustment more intelligentized and humanized.
5. Built-in sync status indicator on the remote control, which can show the bright status of the LED synchronously.
6. Color changing scene mode and preset storage function.
7. USB charging port.

## 3. Product Size:

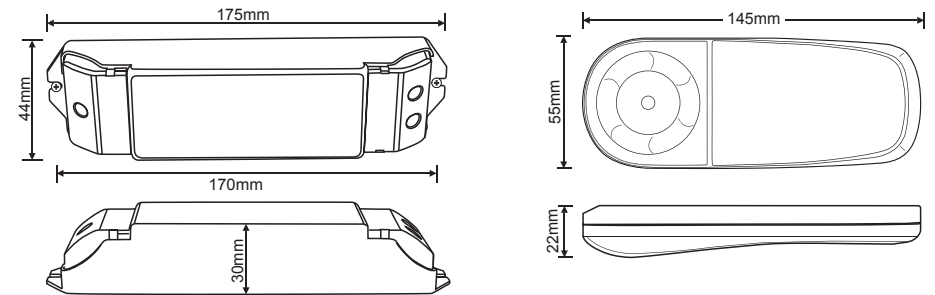

## 4. Components Description for Receiver and Remote Control:

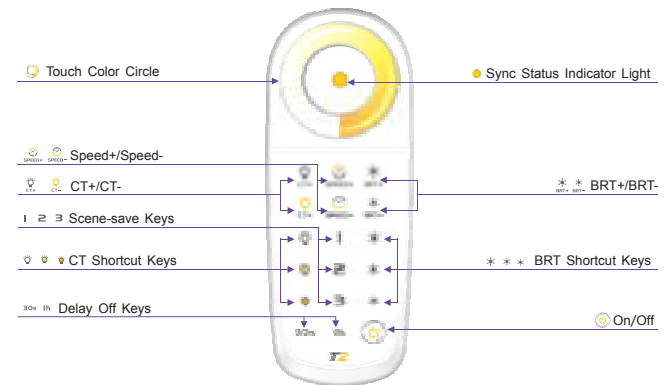

## 5. The Charging Methods for Remote Control:

1. When charging, please connect USB cable to the mobile charger or computer with the USB interface.
2. The blue indicator light flickers while charging, and turns green means the charging is completed. The remote control can be chargeable even at the OFF state, on which the indicator light is black.
3. No memory effect in the lithium battery of remote control. Follow the standard charging procedure even for the first three times, no need over charge.
4. Red indicator light flickers meaning low battery and need to be charged. Charging in low battery will affect life of battery.
5. Please make sure more than 40% battery remaining on the remote control for long time no use, and it needs to be charged at least every half year, otherwise the capacity of the battery would be decreased or the battery gets damaged.

## 6. Detailed Key Functions:

The remote control has 18 function keys and 1 touch color circle.









### The learning of remote control:

Press "ID learning button"  on the receiver for 2 seconds, there is a buzzer sound, now according to the following steps learning ID and deleting ID:

**Learning ID:** Press any key on the remote control within 5 seconds, until the green LED indicator light  flashes 3 times (a voice prompt at the same time), means the controlling between the remote control and receiver is activated, release the button on the receiver and remote control when the learning is finished.

 If you want to control multiple receivers synchronously, just follow the above instructions for each receiver.

**Cancelling ID:** Press any key on the remote control over 5 seconds, until the red LED indicator light  flashes 3 times (a voice prompt at the same time), means the controlling between the remote control and receiver is cancelled, release the button on the receiver and remote control when the deleting is finished.

Remote Control Sign	Key	Description
	<b>ON/OFF</b>	<ul style="list-style-type: none"> <li>• Turn on or turn off the receiver.(turn on or turn off light)</li> </ul>
	<b>CT+/CT-</b>	<ul style="list-style-type: none"> <li>• Press the keys to increase or decrease the color temperature of the LED.</li> <li>• Keep pressing to adjust the color temperature continuously.</li> </ul>
	<b>SPEED+ SPEED-</b>	<ul style="list-style-type: none"> <li>• Press either key to enter the color temperature gradual mode.</li> <li>• Press again to increase or decrease the gradual speed.</li> </ul>
	<b>BRT+ BRT-</b>	<ul style="list-style-type: none"> <li>• Press the keys to adjust the brightness.</li> <li>• Keep pressing to adjust brightness continuously.</li> </ul>
	<b>CT SHORTCUT KEYS</b>	<ul style="list-style-type: none"> <li>• Press the keys to quickly select the high, medium or low color temperature status.</li> </ul>
	<b>SCENE-SAVE KEYS</b>	<ul style="list-style-type: none"> <li>• Long press for 3 seconds to memorize the current color temperature status. Can memorize three groups' color temperature status in total.</li> </ul>
	<b>BRT SHORTCUT KEYS</b>	<ul style="list-style-type: none"> <li>• Press the keys to quickly select the high, medium or low level of brightness for current color temperature.</li> </ul>
	<b>DELAY OFF KEYS</b>	<ul style="list-style-type: none"> <li>• Press the keys to delay power off (or turn off the lights) in 30 seconds or 1 hour.</li> </ul>

★Other function: press "DELAY OFF KEY"  in 3 seconds, the buzzer can be on or off.

## 7. System Diagram:

 Unlimited receivers can be installed within effective distance, no wiring needed between the receivers, which can be less or more in quantity according to your need for the installation, if you want to increase or decrease the receivers, just activate or cancel the control ID on the remote control will be fine, no any changes and effects on the other receivers.

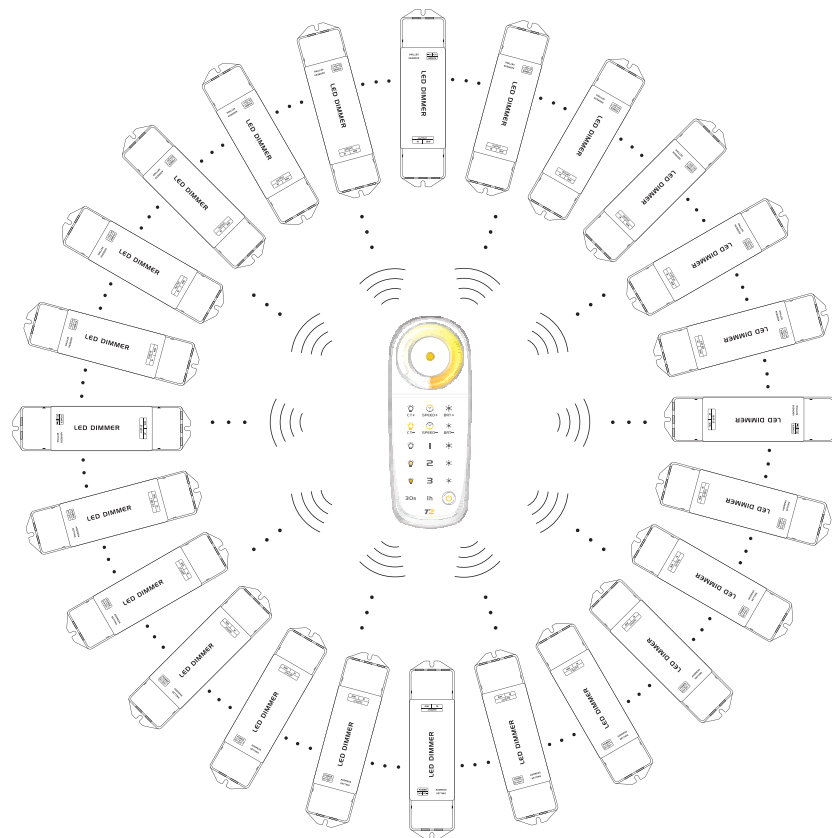

## 8. Wiring Diagram:

1. Multiple Receivers are Powered by One Power Supply :

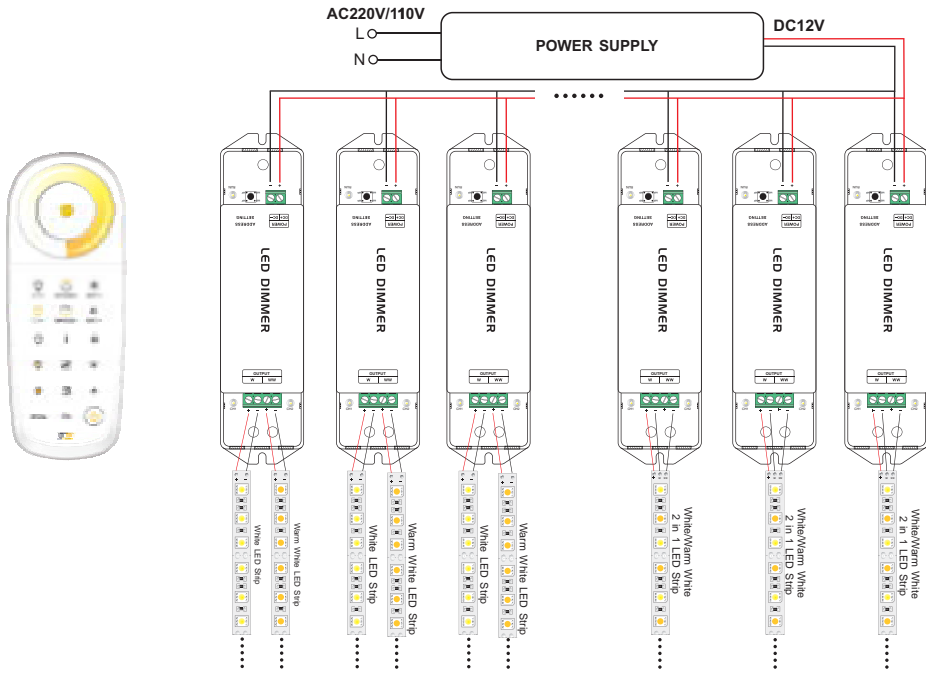

2. Each Receiver is Powered by One Power Supply Independently :

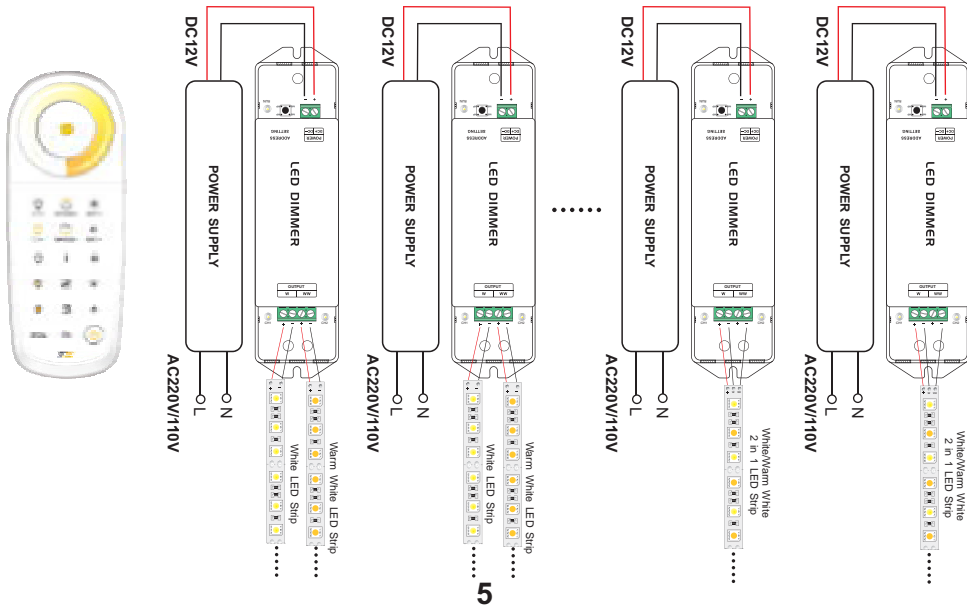

## 9. Attention:

1. The product shall be installed and serviced by a qualified person.
2. This product is non-waterproof. Please avoid the sun and rain. When installed outdoors please ensure it is mounted in a water proof enclosure.
3. Good heat dissipation will prolong the working life of the controller. Please ensure good ventilation.
4. Please check if the output voltage of any LED power supplies used comply with the working voltage of the product.
5. Please ensure that adequate sized cable is used from the controller to the LED lights to carry the current. Please also ensure that the cable is secured tightly in the connector to avoid the accidents due to overheat and poor contact on the wire.
6. Ensure all wire connections and polarities are correct before applying power to avoid any damages to the LED lights.
7. If a fault occurs please return the product to your supplier. Do not attempt to fix this product by yourself.

## 10. Warranty Agreement:

1. We provide lifelong technical assistance with this product:

- A 3-year warranty is given from the date of purchase. The warranty is for free repair or replacement and covers manufacturing faults only.
- For faults beyond the 3-year warranty we reserve the right to charge for time and parts.

2. Warranty exclusions below:

- Any man-made damages caused from improper operation, or connecting to excess voltage and overloading.
- The product appears to have excessive physical damage.
- Damage due to natural disasters and force majeure.
- Warranty label, fragile label and unique barcode label have been damaged.
- The product has been replaced by a brand new product.

3. Repair or replacement as provided under this warranty is the exclusive remedy to the customer. LTECH shall not be liable for any incidental or consequential damages for breach of any stipulation in this warranty.

4. Any amendment or adjustment to this warranty must be approved in writing by LTECH only.

★This manual only applies to this model. LTECH reserves the right to make changes without prior notice.