

## Features

- 5-in-1 dual-button remote control, support 1-5 color LED control, suitable for single color, color temperature, RGB, RGBW or RGB+CCT LED controller.
- Turn the light on/off, adjust the brightness, color temperature, and RGB color by pressing the buttons.
- Operate with LED indicator light.
- CR2032 battery powered.
- Black & Grey-white available.

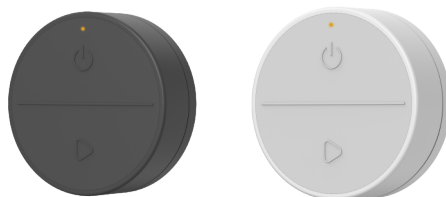

CE RoHS

## Technical Parameters

| Input and Output |                         | Environment           |                                | Safety and EMC  |   |
|------------------|-------------------------|-----------------------|--------------------------------|-----------------|---|
| Output signal    | RF 2.4GHz               | Operation temperature | T <sub>a</sub> : -30°C ~ +55°C | EMC standard    | EN IEC 55015/<br>EN IEC 61547<br>ETSI EN 301 489-1/-3 |
| Work voltage     | 3VDC(CR2032)            | IP rating             | IP20                           | Safety standard | EN 61347-1/-2<br>EN 62493                             |
| Work current     | <8mA                    | <b>Package</b>        |                                | Radio equipment | ETSI EN 300 440                                       |
| Standby current  | <2μA                    | Size                  | L50 x W50 x H32mm              | Certification   | CE RoHS   |
| Control distance | 30m(Barrier free space) | Gross weight          | 0.04kg                         |                 |   |
| <b>Warranty</b>  |                         |                       |                                |                 |   |
| Warranty         | 5 years                 |                       |                                |                 |   |

## Mechanical Structures and Installations

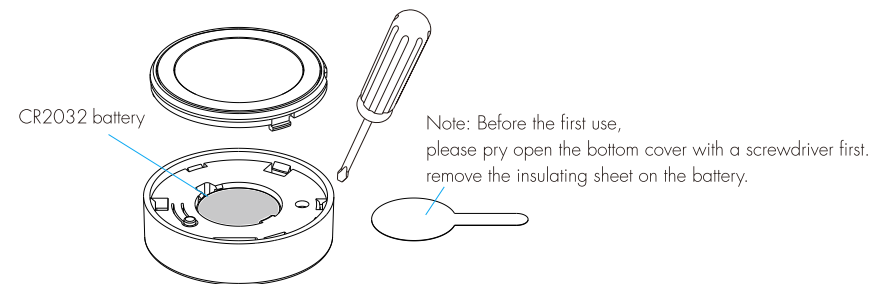
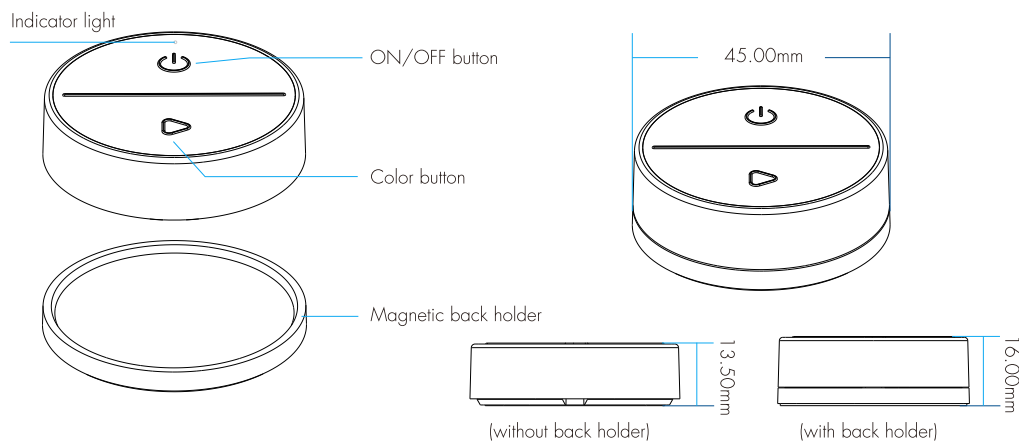

There are two ways to fix the remote control:

- 1: The remote control can be attached directly to metal surfaces.
- 2: Secure the remote control back holder to the wall with 3M adhesive.

## Light Type Setting

Long press set button 2s to switch 5 light types in sequence.

1. When set to DIM light type, the LED indicator light flash 1 time.
2. When set to CCT light type, the LED indicator light flash 2 times.
3. When set to RGB light type, the LED indicator light flash 3 times.
4. When set to RGBW light type, the LED indicator light flash 4 times.
5. When set to RGB+CCT light type, the LED indicator light flash 5 times.

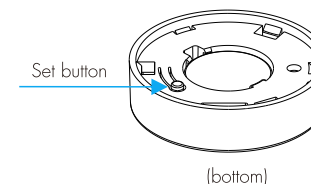

The factory default light type is DIM.

When the battery of the remote control is replaced and the power is restored, the indicator light will flash the corresponding number of times according to the current light type.

## Match Remote Control

End user can choose the suitable match/delete ways. Two options are offered for selection:

### Use the controller's Match key

**Match:**  
Short press match key of the controller, immediately short press the ON/OFF button on the remote controller.  
The LED indicator fast flash a few times means match is successful.

**Delete:**  
Press and hold match key of the controller for 5s to delete all match.  
The LED indicator fast flash a few times means all match were deleted.



### Use Power Restart

**Match:**  
Switch off the power of the controller, then switch on power, repeat again.  
Immediately short press the ON/OFF button on the remote controller 3 times.  
The light blinks 3 times means match is successful.



**Delete:**  
Switch off the power of the controller, then switch on power, repeat again.  
Immediately short press the ON/OFF button on the remote controller 5 times.  
The light blinks 5 times means all matched remotes was deleted.

## Key Function



### DIM light type

-  Short press: Turn on/off the light.  
Long press (1-6s): Adjust the brightness continuously.
-  Short press: Sequential switching of 5 levels of brightness (10%, 25%, 50%, 75%, 100%).



### CCT light type

-  Short press: Turn on/off the light.  
Long press (1-6s): Adjust the brightness continuously.
-  Short press: Sequential switching 5 levels color temperature (warm white - neutral white - cool white).  
Long press (1-6s): Adjust the color temperature continuously.



### RGB light type

-  Short press: Turn on/off the light.  
Long press (1-6s): Adjust the brightness continuously.
-  Short press: Switch between static color light (RGB) and mixed white light (current color light + 50% saturation).  
at the same time, enter the state of long press to adjust color light or saturation.  
Double click: Switch multiple dynamic change modes in sequence,  
at the same time, enter the long press to adjust speed state.  
Long press: In the static color light mode, adjust the color continuously .  
In the static mixed white light mode, adjusts saturation continuously.  
In dynamic change mode, long press 2s to switch 5 levels speed sequentially.

### RGBW light type

-  Short press: Turn on/off the light.  
Long press (1-6s): Adjust the brightness continuously.
-  Short press: Switch between the static color light(RGB) and white light(WW),  
at the same time, enter the state of long press to adjust color light or color temperature.  
Double click: Switch multiple dynamic change modes in sequence,  
at the same time, enter the long press to adjust speed state.  
Long press: In the static color light mode, adjust the color continuously.  
In the static white light mode, adjusts the white brightness continuously.  
In dynamic change mode, long press 2s to switch 5 levels speed sequentially.

### RGB+CCT light type

-  Short press: Turn on/off the light.  
Long press (1-6s): Adjust the brightness continuously.
-  Short press: Switch between the static color light (RGB) and color temperature.  
at the same time, enter the state of long press to adjust color light or color temperature.  
Double click: Switch multiple dynamic change modes in sequence,  
at the same time, enter the long press to adjust speed state.  
Long press: In the static color light mode, adjust the color continuously.  
In the static color temperature light mode, adjust the color temperature continuously.  
In dynamic change mode, long press 2s to switch 5 levels speed sequentially.

## Safety Information

1. Read all instructions carefully before you begin this installation.
2. When installing battery, pay attention to the battery positive and negative polarity.  
A long time without the remote control, remove the battery.  
When remote distance becomes smaller and insensitive, replace the battery.
3. If no response from the receiver, please re-match the remote.
4. Gently handle remote, beware of falling.
5. For indoor and dry location use only.
6. Remove and immediately recycle or dispose of used batteries according to local regulations and keep away from children.  
Do NOT dispose of batteries in household trash or incinerate.
7. Even used batteries may cause severe injury or death.
8. Call a local poison control center for treatment information.
9. Compatible battery type is CR2032 and the nominal battery voltage is 3V.
10. Non-rechargeable batteries are not to be recharged.
11. Do not force discharge, recharge, disassemble, heat above 55°C or incinerate.  
Doing so may result in injury due to venting, leakage or explosion resulting in chemical burns.
12. Ensure the batteries are installed correctly according to polarity (+ and -).
13. Do not mix old and new batteries, different brands or types of batteries, such as alkaline, carbon-zinc, or rechargeable batteries.
14. Remove and immediately recycle or dispose of batteries from equipment not used for an extended period of time according to local regulations.
15. Always completely secure the battery compartment. If the battery compartment does not close securely, stop using the product, remove the batteries, and keep them away from children.