

Диммер SR-EUT0802 (220V, 8x2A, DALI, DMX)



3 Technical Parameters

| Item | Parameters |
|-------------------------|--|
| Input control signal | DMX512(1990)/RDM, DALI and EU-BUS signal |
| Input voltage | 100-240VAC 50/60Hz |
| Max output current | 2A*8ch |
| Equipment size | 222.5*93.4*63.2mm(L*W*H), standard 35mm din rail |
| Pack size | 230*104*72mm(L*W*H) |
| G.W. | 1050g |
| Operational temperature | -20-50°C |

3.1 Dimension(mm)

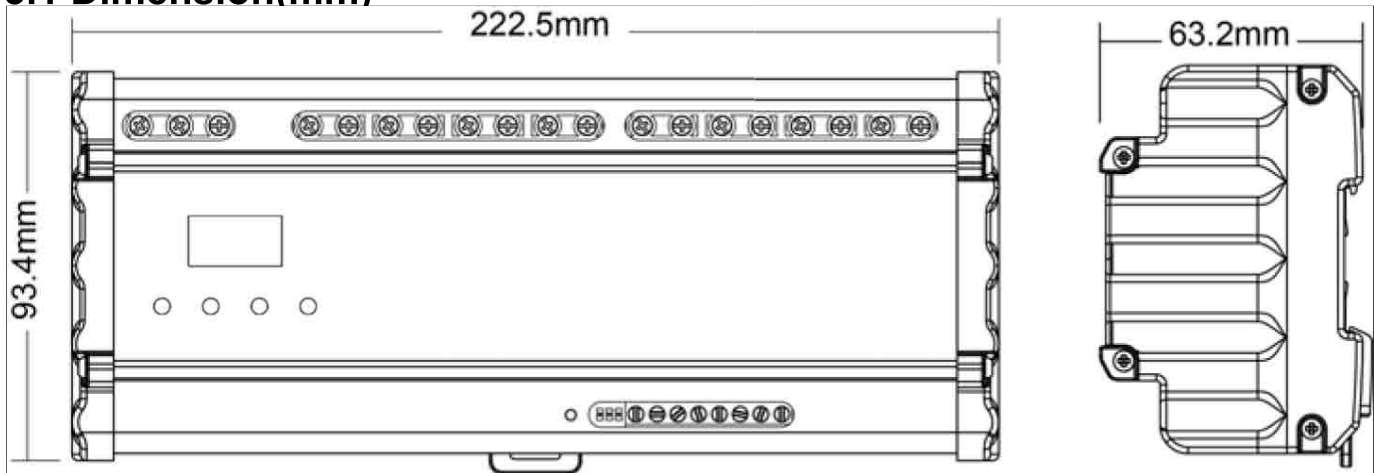

4 Function Show of the Product

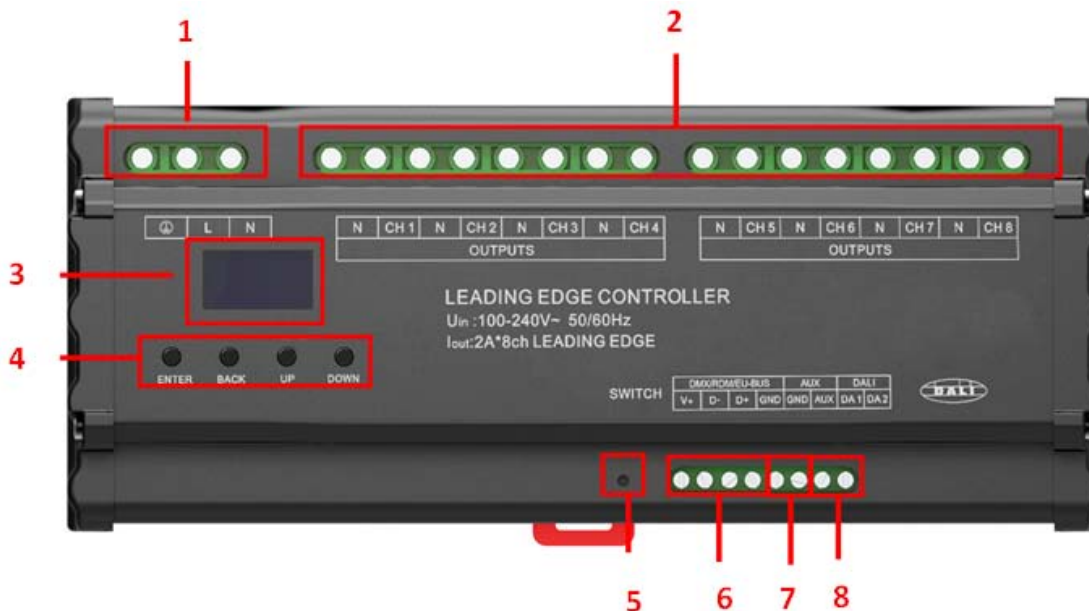

Figure 1

| | |
|---|---|
| 1 | AC input port |
| 2 | output 8 channel leading edge or switch control |
| 3 | LCD display |

1 Summary

Thanks for using our phase cut controller. Leading edge controller is a multi-function triac dimmer Control mode of controller is flexible, which complies with 4 control protocols:

- 1, support the international widely adopted DMX-512 (1990) /RDM and DALI standard protocol, and can access to KNX, Dyalite, Lutron, Crestron, LDS and other intelligent dimming network via gateway.
- 2, support EU-BUS lighting control protocol. It can be used with relay switch controller, clock module, panel module, sensor module to achieve the group and scene control. This solution is widely used in the family, conference rooms, hotels, schools, and other occasions.
- 3, support Touchdim, manual control, timing control function (optional).The user can manually turn ON/OFF or dim the brightness.

1.1 Ordering Information

| Model | DALI | DMX/RDM | EU-BUS | Manual control | Timer function |
|------------|------|---------|--------|----------------|----------------|
| SR-EUT0802 | Y | Y | Y | Y | N |

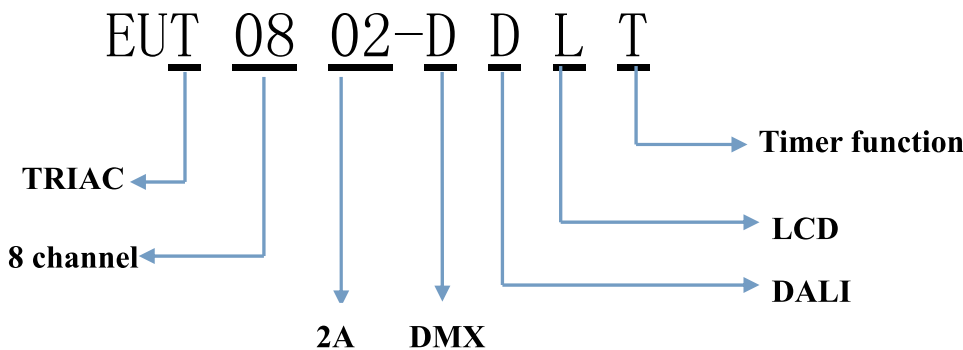

2 Product Features

- Meets DMX512(1990)/RDM,DALI IEC62386 protocol, and EU-BUS
- With LCD display and manual button, the user can operate more conveniently
- Output 8 channel phase cut or switch control, max current of each channel is 2A
- 6.3A fuse delay protection for each 2 outputs
- Output 12VDC,supply for control system
- Set fade time of each channel separately, range of 0.1-10s
- Standard 35 mm din rail, convenient installation
- Can save up to 8 events(Only for EUT0802-DDLT)
- suitable for use with TRIAC dimming driver, incandescent, low voltage, etc.

3 Technical Parameters

| Item | Parameters |
|-------------------------|--|
| Input control signal | DMX512(1990)/RDM, DALI and EU-BUS signal |
| Input voltage | 100-240VAC 50/60Hz |
| Max output current | 2A*8ch |
| Equipment size | 222.5*93.4*63.2mm(L*W*H), standard 35mm din rail |
| Pack size | 230*104*72mm(L*W*H) |
| G.W. | 1050g |
| Operational temperature | -20-50°C |

3.1 Dimension(mm)

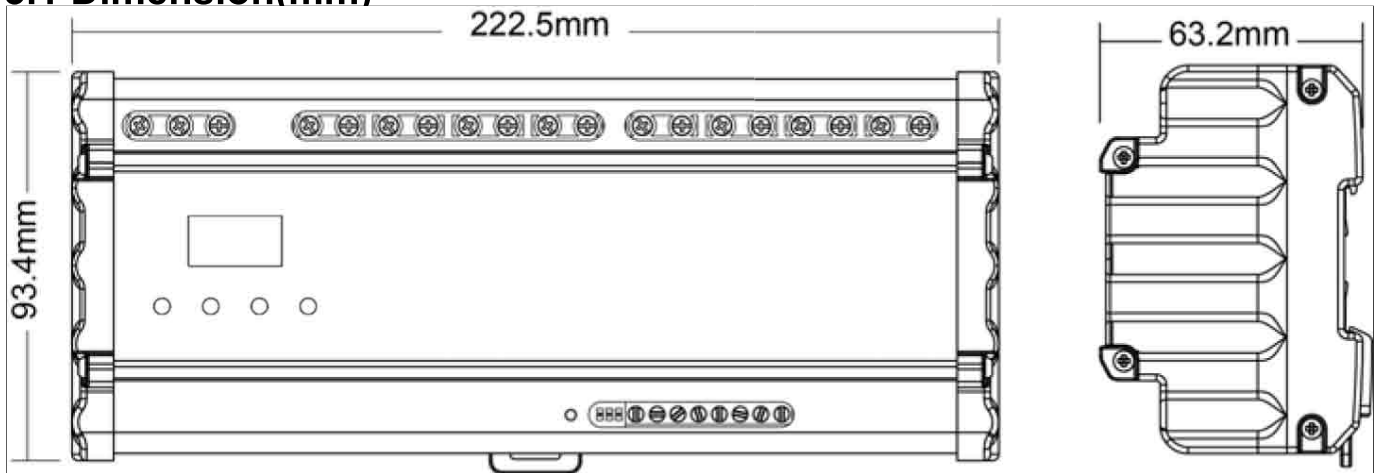

4 Function Show of the Product

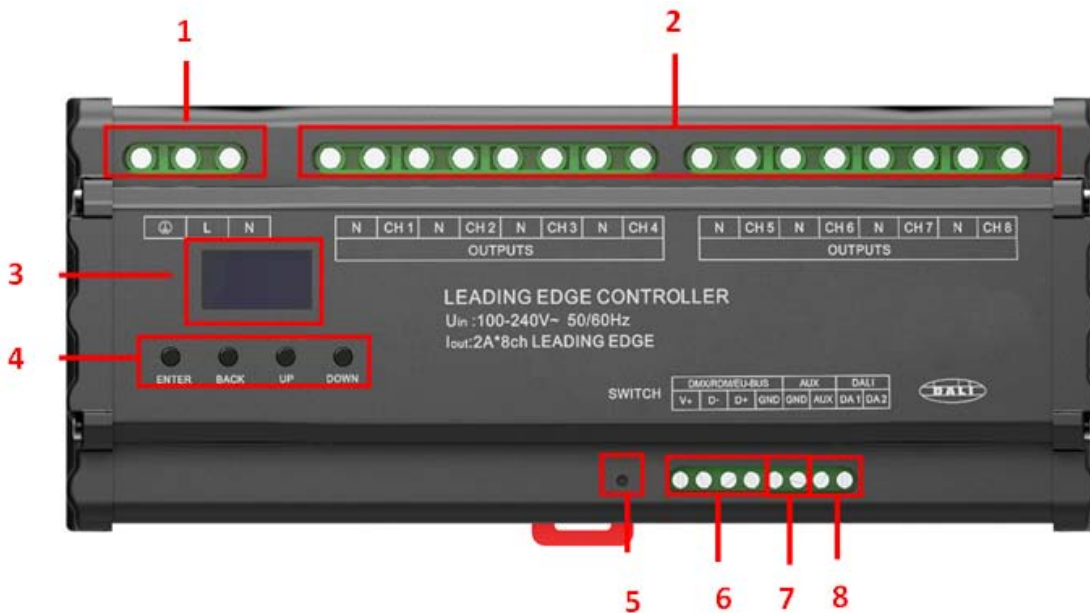

Figure 1

| | |
|---|---|
| 1 | AC input port |
| 2 | output 8 channel leading edge or switch control |
| 3 | LCD display |

| | |
|---|---|
| 4 | Function button |
| 5 | Button, press for 4s or more, the device will restart |
| 6 | 12V output port(supply for control system),and DMX512/RDM,EU-BUS port |
| 7 | Dry contact signal |
| 8 | DALI signal port |

5 LCD Function

After the device is powered, the main menu will be seen, including control mode, output mode, time event, system settings and system information ,see figure 2 and figure 3. Press the button "Enter" to enter the sub menu, press "BACK" to return to the upper menu, press "UP" or "DOWN" button to move the cursor up or down.

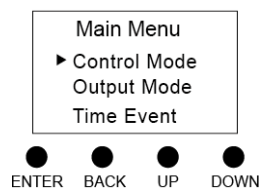

Figure 2

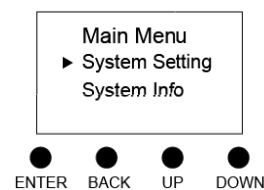
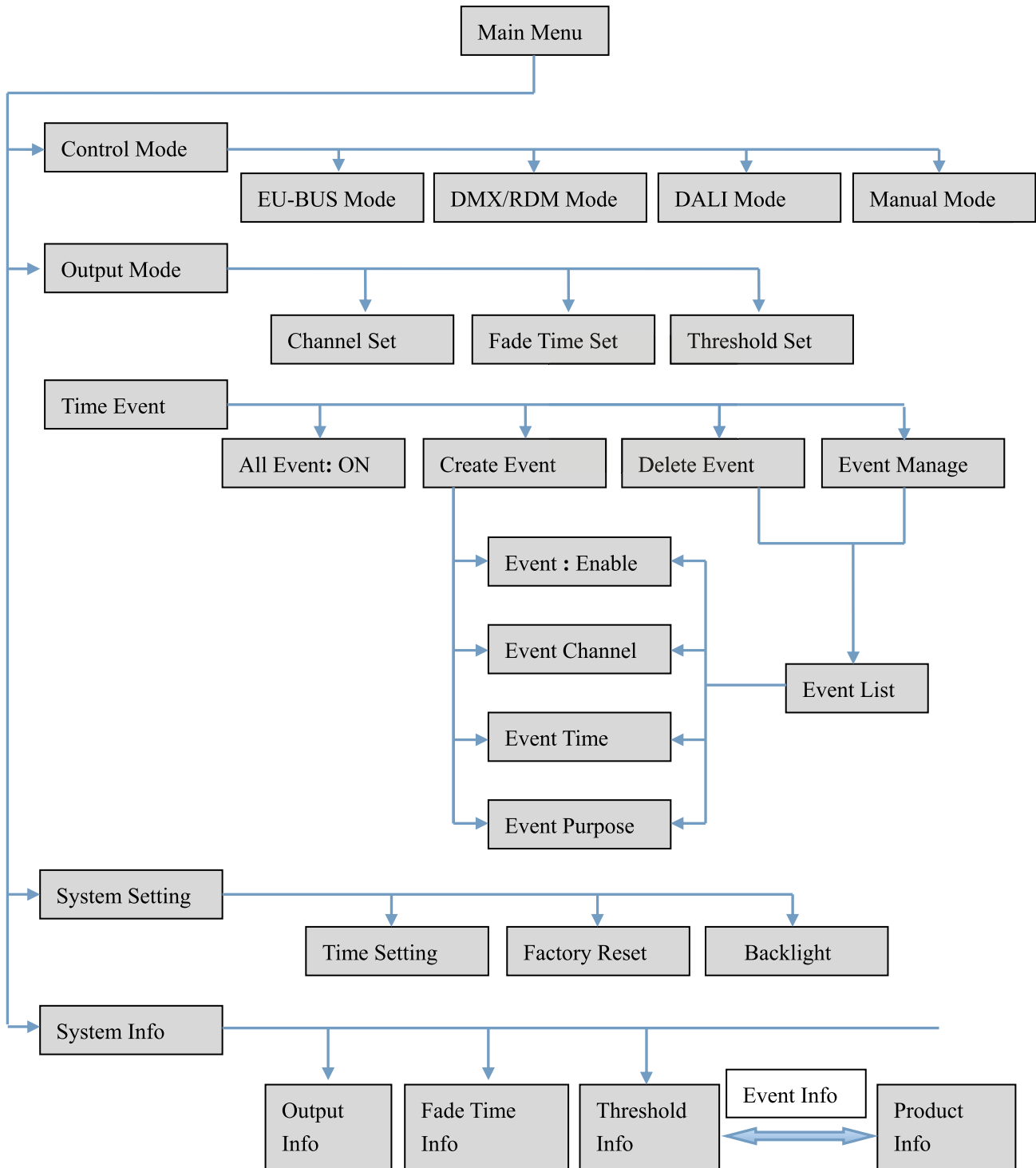

Figure 3

| Button | Function |
|--------|---|
| ENTER | Confirm key, confirm the selected state, enter the option to set the state |
| BACK | Return key, quit the option, return to the upper menu, |
| UP | Move up the cursor; change the status of the option; when setting DMX Address, Threshold, Fade Time, long press "UP", the value will increase rapidly |
| DOWN | Move down the cursor; change the status of the option; when setting DMX Address, Threshold, Fade Time, long press "DOWN", the value will decrease rapidly |



5.1 Control Mode

5.1.1 EU-BUS mode

In the current mode, the output signal is controlled by EU-BUS command, the host computer can scanning equipment, assign the box number, read parameters, update the firmware of equipment. The device can operate according to the instruction of the upper computer.

Select the EU-BUS mode, press the “ENTER” can view the device code, the box number, serial number (GUID), press “BACK” to return to the upper menu.

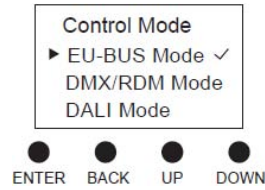

Figure 4

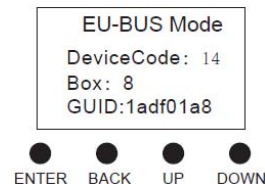

Figure 5

5.1.2 DMX/RDM mode

In the current mode, the output signal is controlled by DMX/RDM.

When using DMX512(1990) protocol, press "ENTER", then set DMX address for each channel, range of 1-511. The addresses of 8 channels are independent of each other, can be the same or different, and can be continuous or discontinuous. To set the same address for all channels, you can control the group.

When using RDM(2009), the upper computer can scan the device, and assign the address, read the parameters.

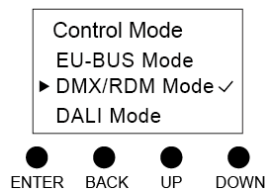

Figure 6

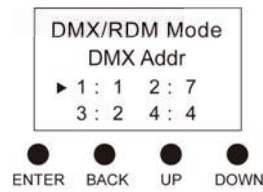

Figure 7

5.1.3 DALI mode

The output signal is controlled by the DALI command in this mode. The address of the DALI mode is assigned by the system itself, but can be modified by the host computer. Press "ENTER" to read the short addresses of 8 channels, The addresses of 8 channels are independent of each other.

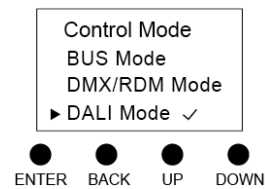

Figure 8

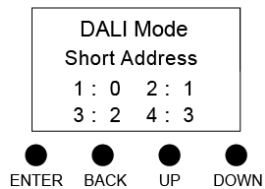

Figure 9

5.1.4 Manual mode

In the current mode, you can manually set the brightness for each channel, range of 0-100%.

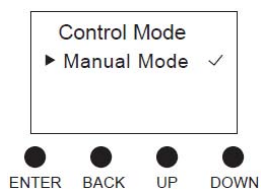

Figure 10

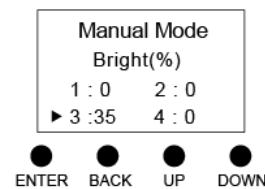

Figure 11

5.2 Output mode

5.2.1 Channel Set

You can choose output type for each channel. There are two output types, SW and LPC.

- a) SW: Switch mode, as the power switch
- b) LPC: To dim leading edge drivers or devices

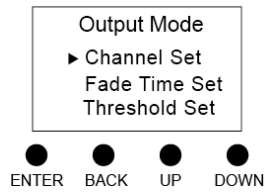

Figure 12

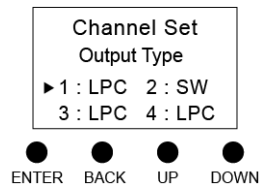

Figure 13

5.2.2 Fade Time

In the current mode, set fade time of each channel. The range is 0-100(Unit:0.1s).

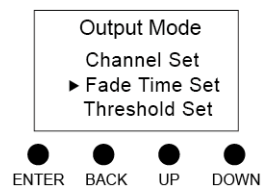

Figure 14

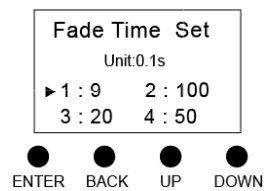

Figure 15

Note1: Fade Time is valid only in LPC mode.

Note2: In EU-BUS mode, Fade Time is invalid, the user can set fade time via software only.

5.2.3 Threshold

You can set the switch threshold for each channel.

In SW mode, when received brightness \geq the threshold value, the corresponding channel output 100% brightness. or else shut down the output.

In LPC mode, the switching threshold is the minimum brightness value. The received brightness value is 0, shut down the output; when received brightness value \leq threshold value, and is not 0, output minimum brightness; when the received brightness value $>$ switch threshold, output the received brightness. The setting range of brightness threshold value is 0-100%.

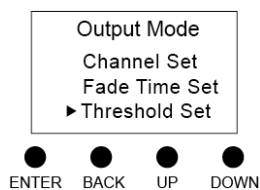

Figure 16

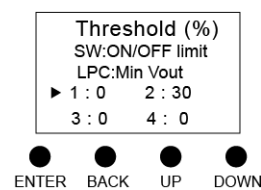

Figure 17

5.3 Time Event(Only for EUT0802-DDLT)

5.3.1 All Event

In the current menu (Figure 19), click "ENTER" to enable the All Event.

When the event switch is "on", activating the function of the event, have created good effective events will be triggered at the set time; opposite, when events switch is "off", functional failure events, all of which have been created the incident will not trigger. Set all the events are valid or invalid.

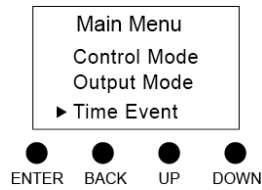

Figure 18

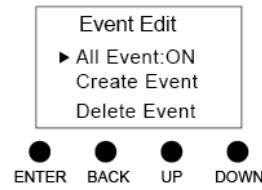

Figure 19

5.3.2 Create Event

Press “ENTER” to create event mode, you can set if this event is valid, and the task of the event ,the trigger time.

5.3.2.1 Event

Set whether this event is valid. Only All Event and Event are valid, the event will be triggered.

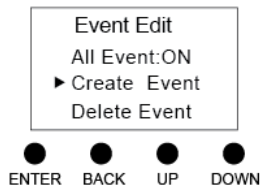

Figure 20

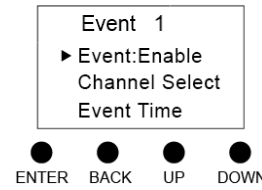

Figure 21

5.3.2.2 Channel Select

Select the channel to be triggered, you can choose one or more channels.

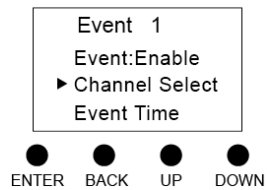

Figure 22

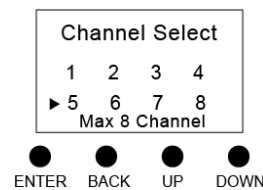

Figure 23

5.3.2.3 Event Time

Set the time to trigger events, including the month, day, week, hour, minute, second.

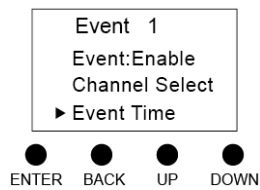

Figure 24

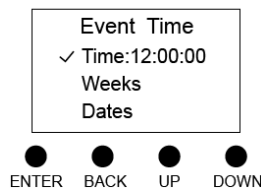

Figure 25

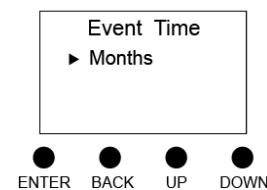

Figure 26

When the event is created, the system automatically names and saves the event, followed by 1,2,3,..... System can save up to 8 events.

5.3.2.4 Event Purpose

Set the event task. In this device, the content of the task is the output brightness, you can set the output brightness of 8 channels separately. The range of brightness is 0-100%

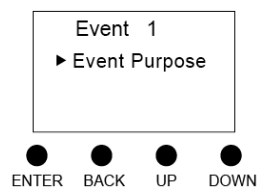

Figure 27

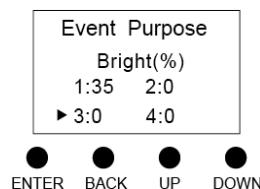

Figure 28

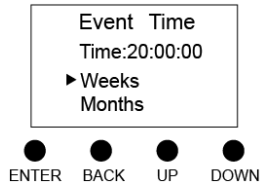

Figure 49

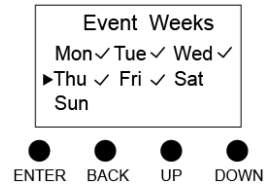

Figure 50

◆ Months: April

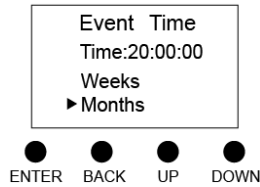

Figure 51

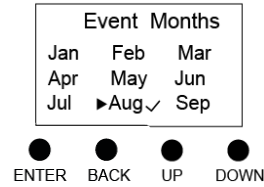

Figure 52

◆ Dates: All

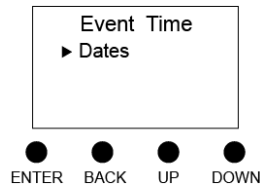

Figure 53

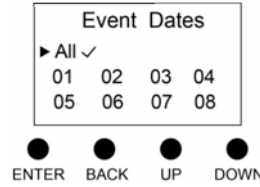

Figure 54

Note: All dates must be selected.

5. Enter "Event purpose" to set the task(output brightness),channel1:80%,channel 2:80%,channel 5:80%

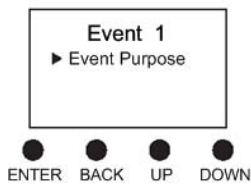

Figure 55

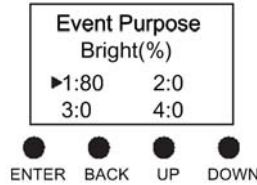

Figure 56

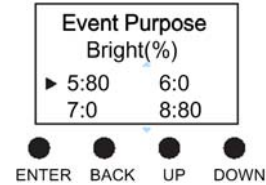

Figure 57

6. After setting up, the system automatically saves and named Event1, the menu of System Info will add one page to show the event details

7. Enter the Event Manage to check or modify the event settings

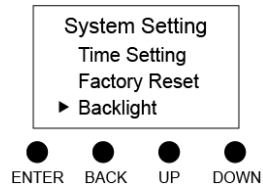

Figure 37

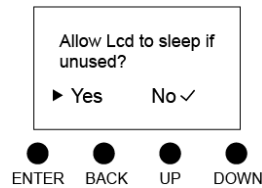

Figure38

5.5 System Info

In this mode, the current system information can be displayed, as follows:

Page1

- Line 2 control mode
- Line 3 show "Output Type"
- Line 4-7 output type of all channels

Page2

- Line 2 control mode
- Line 3 show "Fade Time"
- Line 4-7 fade time of all channels

Page3

- Line 2 control mode
- Line 3 show "Threshold"
- Line 4-7 threshold of all channels

Page 4-Last second page(Only for EUT0802-DDLT)

- Line 2 "All Event" and the state of all event
- Line 3 "Current Event:" event number/total event number
- Line 4 "S:" ,the state of current event, and the trigger time
- Line 5 "Enable CH:"
- Line 6-7 Event task

The last page

- Line 2 Product model
- Line 3 Firmware creation date
- Line 4 Firmware creation time

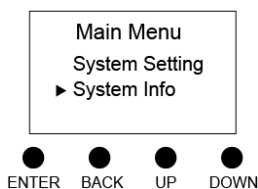

Figure 39

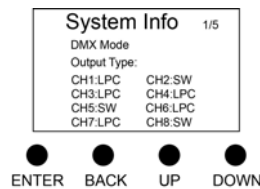

Figure40

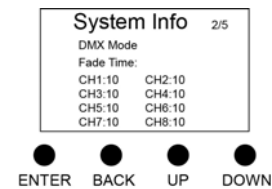

Figure 41

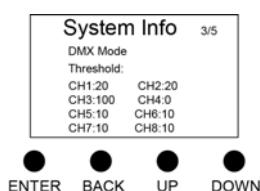

Figure 42

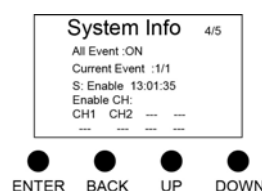
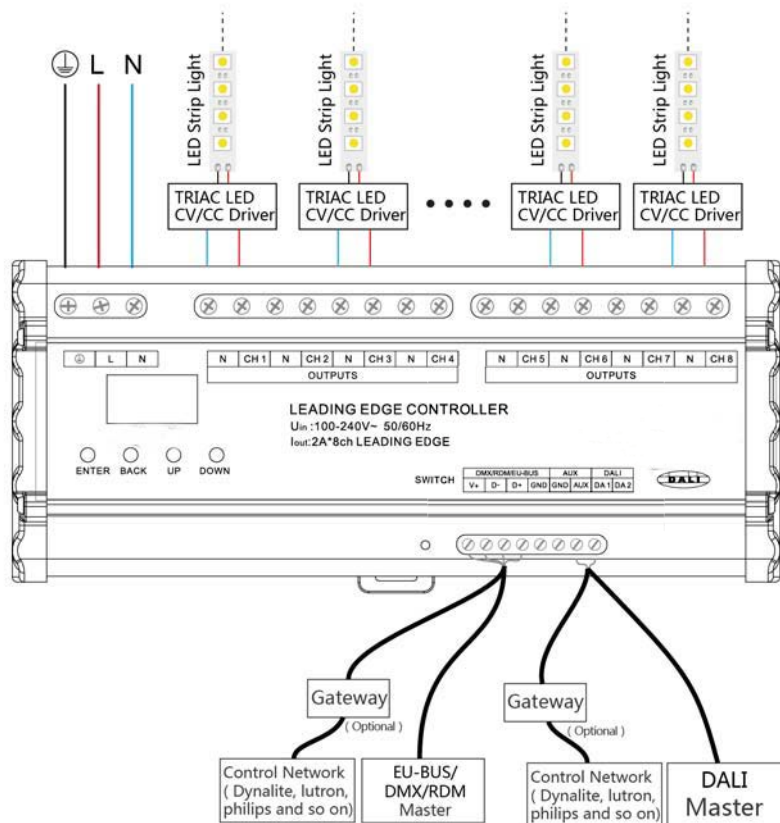

Figure43



Figure 44

6 Wiring Diagram



7 Event Case

The following example details the event settings. For example, channel 1,5,8 output 80% brightness at 8:00pm in April, from Monday to Friday. The setting method is as follows:

1. Set All Event to ON by pressing “ENTER”
2. Enter the Create Event, set Event to Enable by pressing “ENTER”.
3. Press “DOWN” to enter channel select ,select the event channel, then, press “BACK” button to return

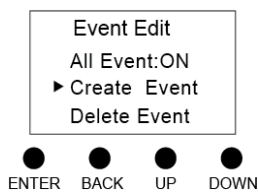

Figure 45

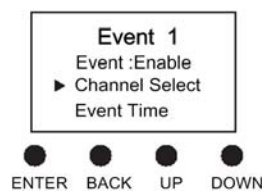

Figure 46

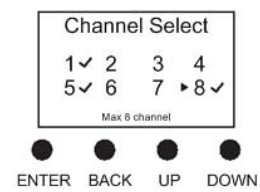

Figure 57

4. Enter the Event Time, set the trigger time, then, press “BACK” button to return

◆ Hour,minute,second:20:00:00

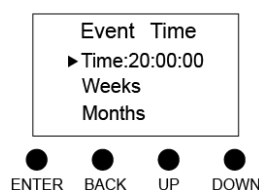

Figure 48

◆ Weeks :from Monday to Friday

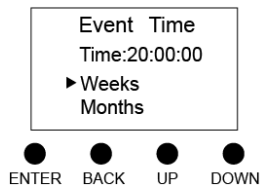

Figure 49

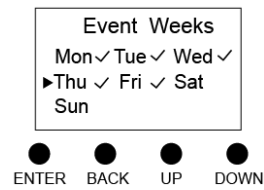

Figure 50

◆ Months: April

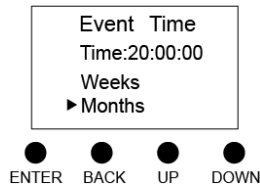

Figure 51

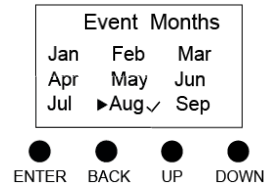

Figure 52

◆ Dates: All

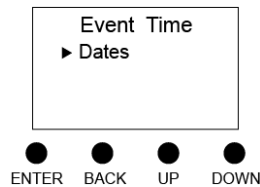

Figure 53

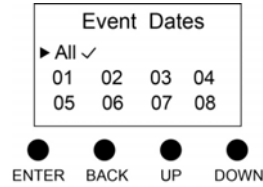

Figure 54

Note: All dates must be selected.

5. Enter "Event purpose" to set the task(output brightness),channel1:80%,channel 2:80%,channel 5:80%

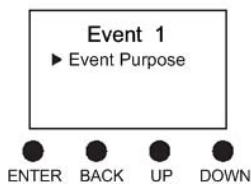

Figure 55

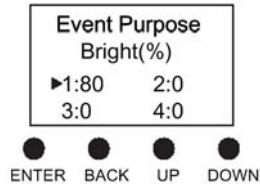

Figure 56

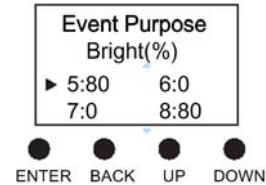

Figure 57

6. After setting up, the system automatically saves and named Event1, the menu of System Info will add one page to show the event details

7. Enter the Event Manage to check or modify the event settings