



UPB2-C(C)
Plastic frame (rounded corners)

UPB2-C(F)
Plastic frame (square corners)

UPB2-C(G)
Tempered glass frame

CE RoHS

Features

- Apply to single color, dual color or RGB/RGBW/RGB+CCT LED controller.
- Each remote can match one or more receiver.
- Operate with LED indicator light.
- CR2032 battery powered.
- Removeable and stick anywhere easily, or mount on wall use panel base.
- Three types of panel frame are available.
- White & Black available.

Technical Parameters

Input and Output		Environment		Safety and EMC	
Output signal	RF 2.4GHz	Operation temperature	Ta: -10°C ~ +55°C	EMC standard	EN IEC 55015/ EN IEC 61547-1/-2 ETSI EN 301 489-1/-17
Working voltage	3VDC (CR2032)	IP rating	IP20	Safety standard	EN 61347-1/-2
Working current	<8mA	Package		Radio equipment	ETSI EN 300 440 ETSI EN 300 328
Standby current	<10µA	Size	L100 x W88 x H30mm	Certification	CE RoHS
Remote distance	30m(Barrier-free space)	Gross weight	0.175kg		
Warranty					
Warranty	5 years				

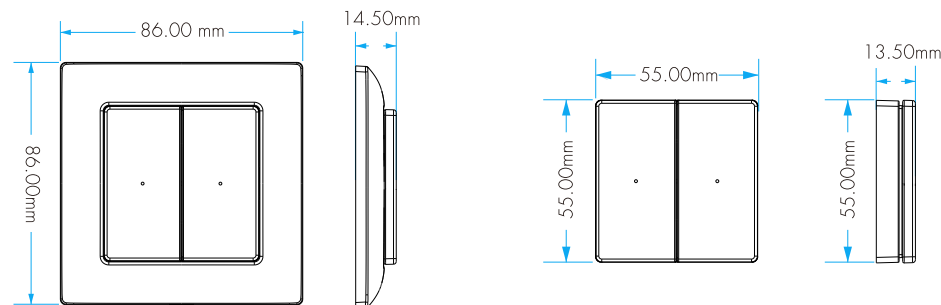

Replace battery:

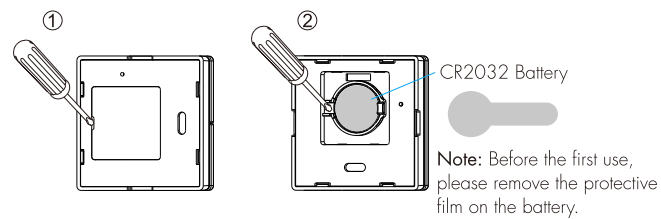

Typical base as below:

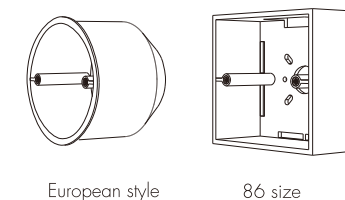

Installation diagram (2 methods):

1. Fix the remote' back holder on the wall with two screws.

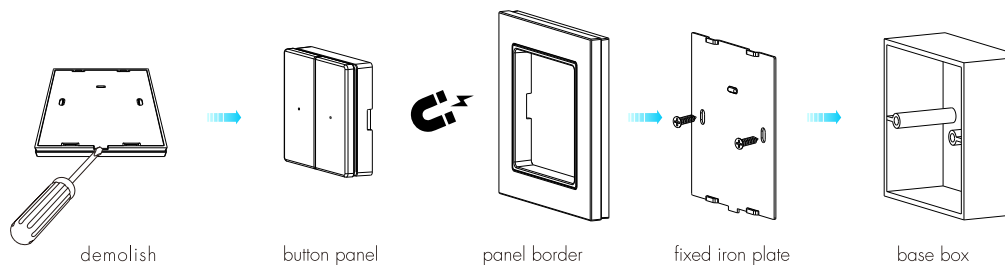

2. Secure the remote control back holder to the wall with 3M adhesive.

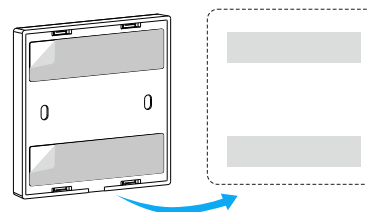

Button Function

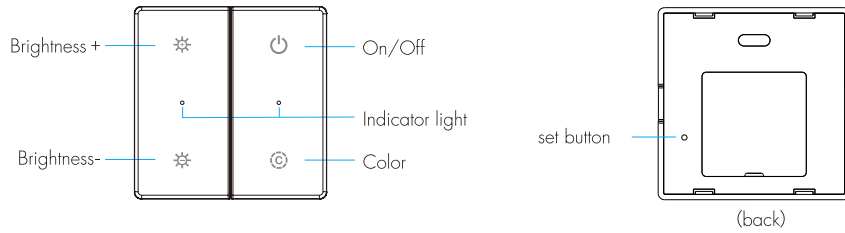

Short press set button to switch 5 light types in sequence.

1. When set to DIM light type, the LED indicator light flash 1 time.
2. When set to CCT light type, the LED indicator light flash 2 times.
3. When set to RGB light type, the LED indicator light flash 3 times.
4. When set to RGBW light type, the LED indicator light flash 4 times.
5. When set to RGB+CCT light type, the LED indicator light flash 5 times.

Press and hold the set button for 2 seconds to restore the default CCT light type.

• DIM light type:

⏻ : Short press to turn on/off the light.

🌈 : Short press to sequential switching of 5 levels of brightness (10%, 25%, 50%, 75%, 100%).

☀️/☀️ : Brightness +/-, short press 10 levels, long press 1-6s to adjust the brightness continuously.

• CCT light type:

⏻ : Short press to turn on/off the light.

🌈 : Color button

Short press: Sequential switching 3 levels color temperature (warm white - neutral white - cool white).

Long press(1-6s): Adjust the color temperature continuously.

☀️/☀️ : Brightness +/-, short press level 10, long press 1-6s to adjust the brightness continuously.

• RGB light type

⏻ : Short press to turn on/off the light.

🌈 : Color button

Short press: Switch between static color light and mixed white light (current color light + 50% saturation). at the same time, enter the long press adjustment mode for color or saturation.

Long press (1-6s): In the s color light mode, adjust the color continuously.
In the mixed white light mode, adjusts saturation continuously.

☀️/☀️ : Short press level 10, long press 1-6s to adjust the brightness continuously.

• RGBW light type

⏻ : Short press, turn on/off the light.

🌈 : Color button

Short press: Switch between the static color light and white light, at the same time enter the state of long press to adjust color light or white brightness.

Long press (1-6s): In color light mode, adjust the color continuously.
In white brightness mode, adjust the brightness of the white light continuously.

☀️/☀️ : Short press 10 levels, long press 1-6s to adjust the brightness continuously.

• RGB+CCT light type

⏻ : Short press to turn on/off the light.

🌈 : Color button

Short press: Switch between the color light and color temperature light.

at the same time, enter the state of long press to adjust color light or color temperature.

Long press (1-6s): In the static color light mode, adjust the color continuously.

In the static color temperature light mode, adjust the color temperature continuously.

☀️/☀️ : Short press 10 levels, long press 1-6s to adjust the brightness continuously.

Match Remote Control

User can choose the suitable match/delete ways. Two options are offered for selection:

Use the Match key

Match:

Short press match key of the controller, immediately short press the ON/OFF button on the remote controller.

The LED indicator fast flash a few times means match is successful.

Delete:

Press and hold match key of the controller for 5s to delete all match.

The LED indicator fast flash a few times means all match were deleted.

Use Power Restart

Match:

Switch off the power of the controller, then switch on power, repeat again.

Immediately short press the ON/OFF button on the remote controller 3 times.

The light blinks 3 times means match is successful.

Delete:

Switch off the power of the controller, then switch on power, repeat again.

Immediately short press the ON/OFF button on the remote controller 5 times.

The light blinks 5 times means all matched remotes was deleted.

Safety Information

1. Read all instructions carefully before you begin this installation.
2. When installing battery, pay attention to the battery positive and negative polarity.
A long time without the remote control, remove the battery.
When remote distance becomes smaller and insensitive, replace the battery.
3. If no response from the receiver, please re-match the remote.
4. Gently handle remote, beware of falling.
5. For indoor and dry location use only.
6. When installing on walls, avoid installing in areas with strong electrical currents.
7. Do not place the device near high-density materials (such as metal or concrete walls) or obstruct it, as this may cause signal attenuation and reduce the remote control range.
8. Remove and immediately recycle or dispose of used batteries according to local regulations and keep away from children.
Do NOT dispose of batteries in household trash or incinerate.
9. Even used batteries may cause severe injury or death.
10. Call a local poison control center for treatment information.
11. Compatible battery type is CR2032 and the nominal battery voltage is 3V.
12. Non-rechargeable batteries are not to be recharged.
13. Do not force discharge, recharge, disassemble, heat above 55°C or incinerate.
Doing so may result in injury due to venting, leakage or explosion resulting in chemical burns.
14. Ensure the batteries are installed correctly according to polarity (+ and -).
15. Do not mix old and new batteries, different brands or types of batteries, such as alkaline, carbon-zinc, or rechargeable batteries.
16. Remove and immediately recycle or dispose of batteries from equipment not used for an extended period of time according to local regulations.
17. Always completely secure the battery compartment. If the battery compartment does not close securely, stop using the product, remove the batteries, and keep them away from children.